

Bishamon[®]

Operation and Service Manual for

TORTOISE III

Model BSC3200KU

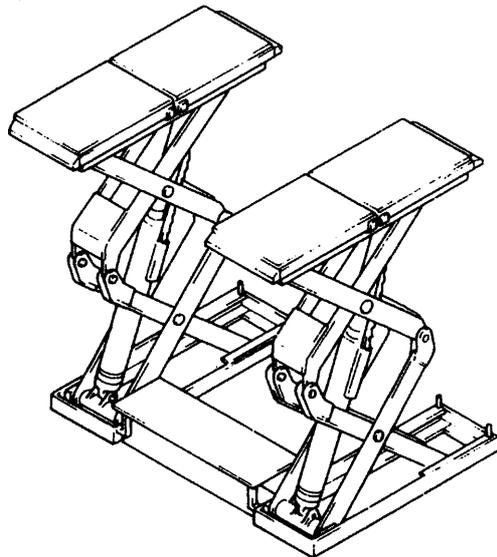

Sugiyasu Corporation
Feb. 2011

Preface

Before operating the lift, READ and be familiar with this operation manual. Incorrect operation by not READING and not being familiar with the operation manual may result in not only poor performing of the lift functions but also the falling of the vehicles and accident of injury or death.

The contents of the manual may differ if the purchased lift is modified. Contact your supplier if the contents of the manual has any unclear statements, error, omission and incorrect collating.



Warning

In this manual, 「Danger」, 「Warning」, 「Caution」 are defined and specified as below. Notice of Warnings are very important for safe operations. As these are very important to protect operators from accident resulting in injury or death, or damage to properties, make certain to understand them fully before operating lift.



Danger

.....Incorrect operation may imminently result in serious injury or death of the operator.



Warning

.....Incorrect operation may result in serious injury or death of the operator



Caution

.....Incorrect operation may result in injury and damage to property. The possibility of occurrence of danger is lower than "Warning" articles.

Contents

| | Page |
|--------------------------------------|---------|
| 1) Objects of the Lift..... | 1 |
| 2) Danger, Warning, Caution..... | 1 ~ 4 |
| 3) Locations of the Labels..... | 5 |
| 4) Components of the Lift..... | 5 ~ 7 |
| 5) Circuit..... | 8 |
| 6) Systems..... | 9 |
| 7) Safety Device..... | 10 |
| 8) Pre-Operation Checks..... | 11 |
| 9) Operation Instruction..... | 12 ~ 13 |
| 10) Clean Up after Service Work..... | 14 |
| 11) Regular Inspection..... | 14 |
| 12) Trouble Shooting..... | 15 ~ 16 |
| 13) Specifications..... | 16 ~ 17 |
| 14) Warranty..... | 18 |
| 15) After Service..... | 19 |
| 16) Installation and relocation..... | 19 |

1 Objects of the Lift

This lift is designed for motor vehicle servicing(excluding one box vehicle and truck type vehicle).

2 Danger, Warning, Caution

Caution for Safety

As these are very important to protect operators from accident resulting in injury and death, and damage to properties, make certain to understand fully before operating lift.

2-1 General Safety Rules to be observed

- 1 Read and be familiar with the operation manual before operating.
- 2 Only trained operators are allowed to use this lift.
- 3 Make certain to perform daily inspections and regular maintenance in accordance with the instructions of operation manual.
- 4 If you suspect that there is any malfunction, do not operate lift and contact your supplier for check.
- 5 This lift is designed for motor vehicle servicing. DO NOT use for any other purposes.
- 6 Do not remove any labels and do not modify.

2-2 Cautions in Operation

The meaning of the mark(symbol) used behind pictures are as below.



The specified act that should not be conducted.



The specified act that should be conducted.



Warning and Caution that is possible to occur due to incorrect operation.



Danger



When lift is operating, DO NOT get under vehicle.
DO NOT allow others to get under vehicle.

It may result in serious injury or death.

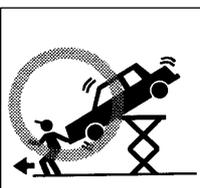

IF THE VEHICLE STARTS TO FALL FROM LIFT, Move away quickly.
DO NOT ATTEMPT TO SUPPORT VEHICLE.

It may result in serious injury or death.



Warning



READ and be familiar with the operation manual for this lift.

The important warnings are described.
Ignoring the warnings may result in serious accidents.



Warning



DO NOT use lift unless you have been trained in its operation.
Incorrect operation may result in accident.

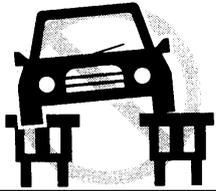

Vehicle must be positioned evenly. DO NOT lift offset vehicle.

When removing parts or with vibration, it may result in falling of the vehicle.

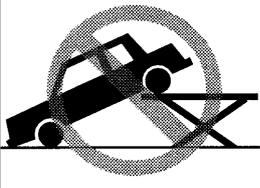

DO NOT lift vehicle by one end or by one side only.

It may result in falling of the vehicle and damage to the vehicle

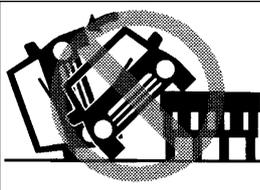

When lifting vehicle, be sure that center of the gravity remains within designated Yellow range.

When removing parts or with vibration, it may result in falling of the vehicle.

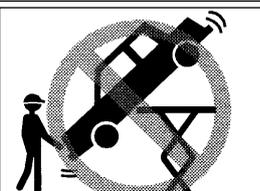

DO NOT swing, shake or push the raised vehicle.

When removing parts or with vibration, it may result in falling of the vehicle.

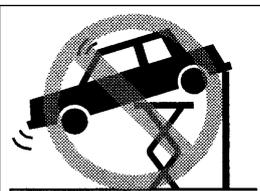

DO NOT lower the lift while any stand or support is in position under vehicle. DO NOT use "Down" motion of lift for any other purpose except lowering(ex. for putting off parts).

Supporter contact may come off and it may result in the falling of the vehicle.



CAUTION!

Removing components may alter center of gravity and cause vehicle to fall.

Supporter contact may come off and it may result in the falling of the vehicle.



KEEP HANDS FREE from lift and vehicle when operating lift.

It may result in pinching hands or serious injury.



Warning



KEEP FEET FREE from lift and vehicle when operating lift.

It may result in pinching feet or serious injury.



DO NOT modify this lift under any circumstances.

It may result in serious accident.



ELECTRICAL HAZARD!

DO NOT open control box or remove cover plates without isolating electrical supply.

It may result in electric shock.



MAKE SURE to DRAIN AIR Filter Regulator before starting operation.

If water drop goes inside of air circuit, lift may not work properly.

It may result in personal injury or property damaging accident.



Caution

Daily Inspections to be performed each day before first operation.

Raise and lower lift without a load and check for any abnormality.

Check for oil or air leakage.

Check air pressure regulator for correct pressure 0.7MPa.

DO NOT USE with higher air pressure, or it may break Air Switching Valve.

Air supply to filter/regulator must not exceed 1.0MPa.

Check for correct operation of electrical controls.

Check that safety devices are well functioning.

Pre-Operation Checks

Only trained operators are allowed to use this lift. Keep others away from lift and controls.

This lift is designed for motor vehicle servicing. DO NOT use for other purposes.

Lift capacity is 3,200 kg. DO NOT attempt to lift heavier loads.

Total load for both left and right sides must be within 3,200 Kgs.

Position Drive-on Plates under correct vehicle lifting points. If vehicle lifting points can not be positively identified then consult vehicle manufacturer's manual. DO NOT lift vehicle if you are in doubt on them.

DO NOT operate lift if safety devices are not functioning.

Check condition of rubber supporters. Keep them clean and free of oil and grease.

When Lifting and Lowering

PAY ATTENTION. Observe the lift operation at all times.

Stop lifting after Drive-on Plates have made firm contact with vehicle and check Drive-on Plates locations and security.

DO NOT use any other supportings but standard Side Sill Block between Drive-on Plates and lifting points.

DO NOT lift loaded vehicles. They may be unbalanced.

DO NOT lift vehicles with passengers inside.

Make sure that safety hooks are engaged before getting under vehicle.

DO NOT lower lift before clearing area of persons and objects.

If vehicle should tilt during lifting or lowering operations;

Lower lift and hold 'Down' button for 5 ~ 10 seconds.

If tilt increases when lowering then contact supplier and do not use lift.

Make sure lift is fully lowered before entering or leaving vehicle.

If lift will not lower, Raise lift and then lower.

When lowering lift with adjustable plate,

(a) Stop lowering when lift is free of vehicle

(b) Remove Side Sill Block and return Drive-on Plates to closed position

(c) Lower lift to floor

Generally

DO NOT modify this lift in any way.

This lift is not weatherproof and is not to be used outdoors or for vehicle washing.

Be cautious at all times. Do not operate lift if you suspect that there is any malfunction.

Maintenance

Always maintain lift in accordance with operation manual.

DO NOT USE THIS LIFT AT ALL IF REPAIRS ARE REQUIRED OR IF YOU SUSPECT ANY MALFUNCTION.

Regular inspections and routine maintenance are essential for the safe operation of this lift.

The procedures are detailed in the operation manual and they must be adhered to.

You must keep a written record of inspections and repairs that includes the date of inspection/repair and the name of the inspector /repairer and details of work done.

3 Location of the Labels

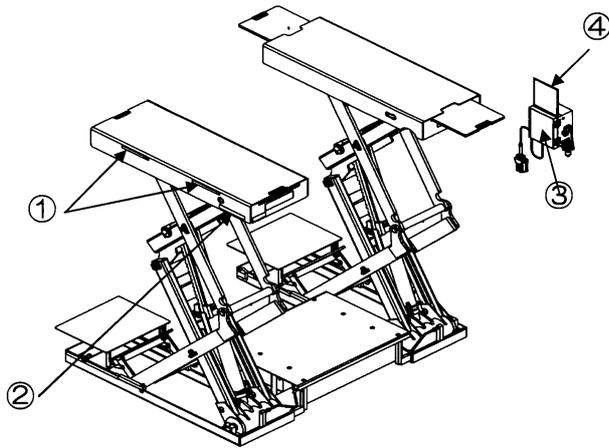

「 Center of Gravity 」 Label
 Capacity label
 Caution Label
 Danger/Warning Label

4 Components of the Lift

BSC3200KU

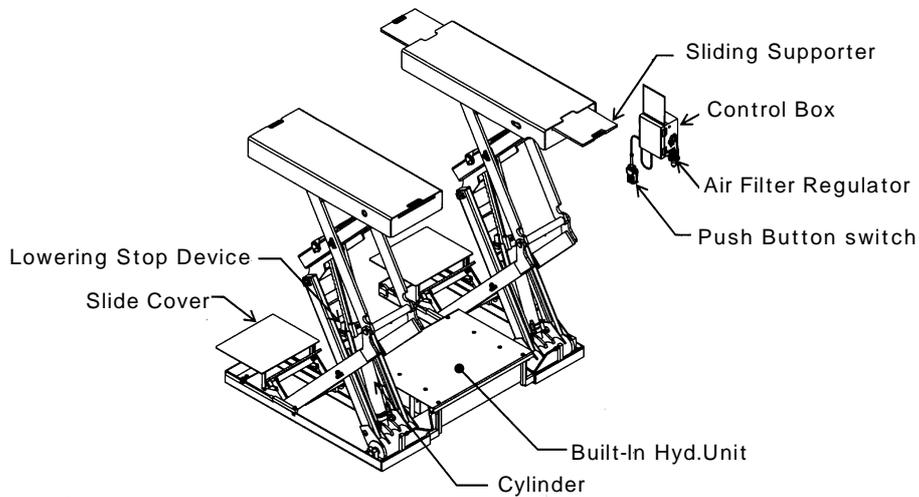

Sliding Supporter

The length of Sliding Supporter can be adjusted between 1320 ~ 1870mm
 Pull the Pulling Grip for sliding.

when folded

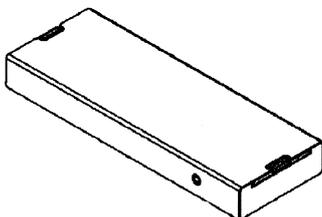

when sliding out

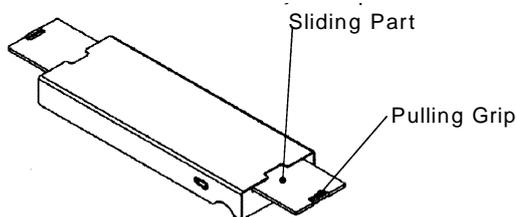

(Air Filter Regulator)

Air Filter Regulator adjusts the supplied air pressure (0.7-1.0MPa) down to appropriate pressure (0.5MPa). It also filters the water in the air.

Pressure Gauge indicates air pressure adjusted by the Regulator.

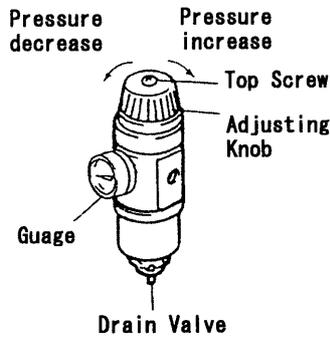

(Air Filter Regulator)

Operation Method

Check if the air pressure supplied to the Regulator is more than 0.7MPa.

Loosen Top Screw first. Then watch Guage and adjust air pressure to 0.7 MPa by turning Adjusting Knob.

turn right: pressure UP

turn left: pressure DOWN

Fix Top Screw after adjusting the air pressure.

How to drain

Push up Drain valve. Water comes out during the valve is pushed up.



Warning

Make sure to drain Air Filter Regulator before starting operation.

If water drop goes inside of air circuit, lift may not work properly, and may result in personal injury or property damaging accident.



Caution

Make sure to check if the pressure at Gauge is 0.5MPa before starting operation.

If the pressure is lower than 0.5MPa, lift may not work properly.

If the pressure is more than 0.5MPa, it may damage Air Switching Valve.



Caution

Supply dry air. If not, lift would be broken.

(Push Button Control Switch)



Warning

It may cause a serious accident if you operate Push Button Control Switch carelessly, without being sure about safety around Lift and vehicle.

Push Button Control Switch is a switch to raise and lower Drive-on Plate.

- By pushing "UP" button, Drive-on Plate goes up.
By releasing the button, the plate stops.
- By pushing DOWN button, Drive-on Plate goes down.
By releasing the button, the plate stops.

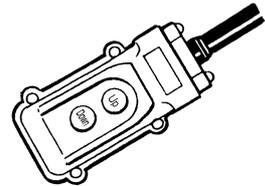

(Side Sill Block)

Side Sill Block is used for protecting side sill of vehicles when lifting up vehicles by Drive-on Plate.

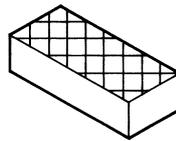

5 Circuit

Hydraulic Circuit

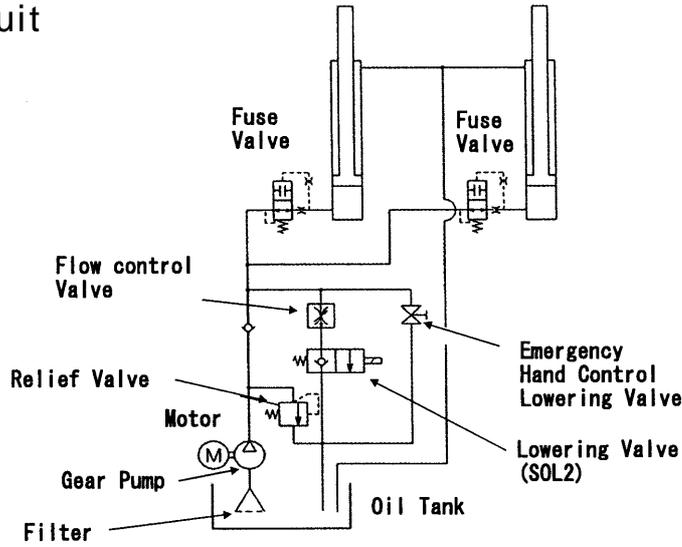

Air Circuit

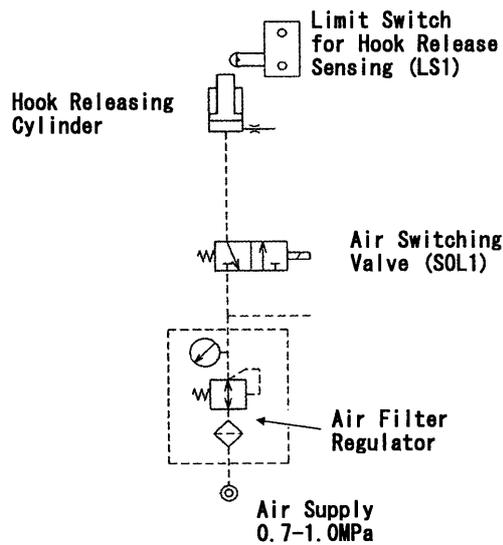

Electric Circuit

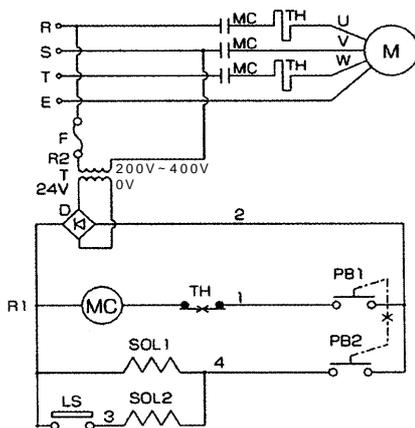

- MC :Magnet Switch
- PB1 :Push Button Switch for raising Lift
- PB2 :Push Button Switch for lowering Lift
- SOL :Air Solenoid Valve for lowering Lift
- SOL2 :Lowering Valve
- LS1 :Limit Switch

6 Systems

Tortoise Lift (NSC series) lifts up Drive-on Plates with Double Scissors Link, using Hydraulic Cylinder worked by Electric Hydraulic Pump.

Both sides of Drive-on Plates synchronize in going up and down as they are connected by Synchronizing Bar.

(Lifting System)

When pushing "UP" button, Motor works. Pump rotates and sends oil into Cylinders. When releasing the button, motor stops. Check Valves prevent oil from coming back from Cylinders. And Cylinders stay at that height level.

(Lowering System)

When pushing "DOWN" button, Air Switching Valve works. The Air Switching Valve sends air into Hook Releasing Cylinders, and the Cylinders release Lowering Stop Hooks.

When both sides of Lowering Stop Hooks are completely released, Limit Switch for Hook Release Sensing electrifies Lowering Valve.

The Lowering Valve opens therefore and Cylinders start lowering.

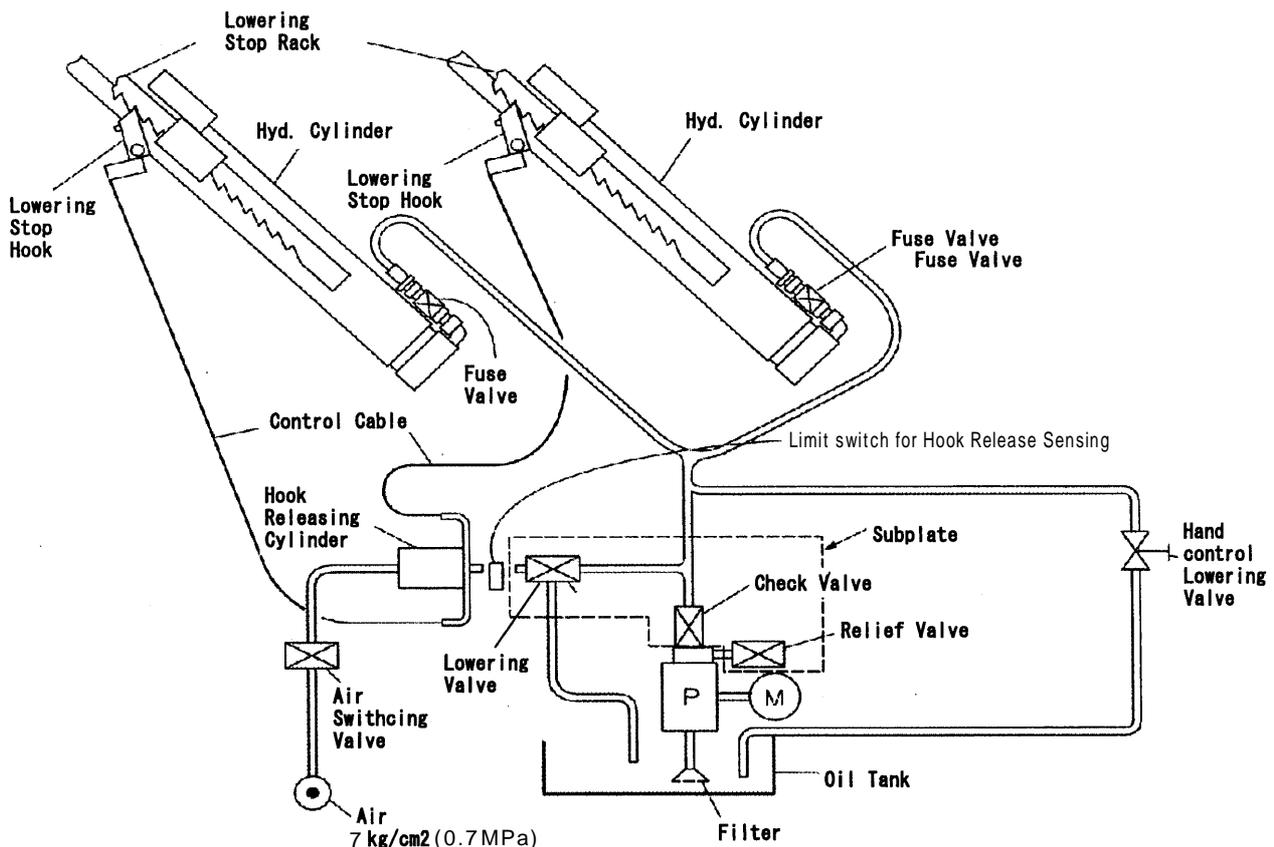

- To lower Drive-on Plates in case of emergency (ex. a power cut) -

Pull out Hook Releasing Cylinder by hand. Keeping Hooks released, loosen slowly Hand

Control Lowering Valve with L-shape hook which was supplied.

7 Safety Device

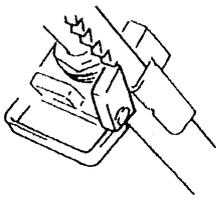
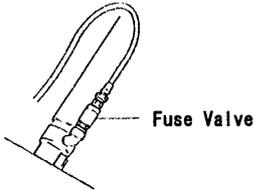
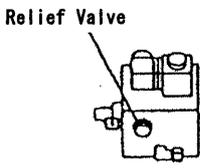
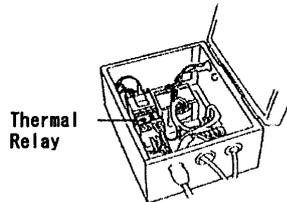
| | | |
|---|--|--|
|  | <p>Lowering Stop Hook</p> | <p>They are installed at each cylinder to prevent lift from falling in case of oil leaking and breakage of hydraulic hose etc. However, please note that there is no Lowering Stop Hook below approx. 500mm from bottom.</p> |
|  | <p>Fuse Valve (Shut Off Valve)</p> | <p>It is installed at each cylinder. It would shut off the oil flow in case sudden flow of oil from cylinder due to the breakage of hydraulic circuit etc.</p> |
|  | <p>Relief Valve</p> | <p>In case of below, it would work to prevent lift from break a.lifting heavier load than lift's capacity b.lift is reaching the top c.pressure in hydraulic line increases due to the trouble for any reason It is installed inside of gear pump.</p> |
|  | <p>Thermal Relay</p> | <p>It would sense the excessive electric current and shut off the the circuit and protect electric components. It is installed at magnetic Switch.</p> |

8 Pre-Operation Checks

Perform the Pre-Operation Checks before operation everyday.
This check must be done without load.

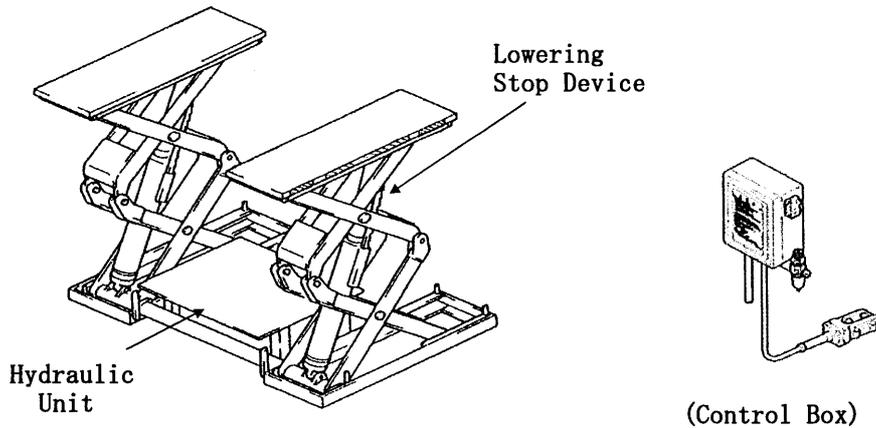

| Point to be checked | Check Items | Check Method | Action if problem is found |
|----------------------|--|---------------------|--------------------------------|
| Lift Unit | Does lift rise and lower smoothly without noise ? | Visual and hearing | Contact supplier |
| Lift Unit | Any damage, strain ? | Visual | Contact supplier |
| Hydraulic Circuit | Any oil leak from cylinder, hyd. unit, piping etc ? | Visual and touching | Tightening or Contact supplier |
| Hydraulic Unit | Any noise from hyd. unit in lifting and lowering? | Hearing | Contact supplier |
| Air Circuit | Any air leak from hook release cylinder, air piping? | Visual and touching | Tightening or Contact supplier |
| Lowering Stop Device | Lowering Stop Hooks work properly? Do the Hooks get released in lowering operation? And keep "IN" position other wise. | Visual | Contact supplier |
| Inside Pit | Any foreign objects in Pit ? | Visual | Remove foreign objects |



Cautions on Air Filter Regulator

Make sure to adjust Air Filter Regulator everyday before operation.
If not, Unit may not work properly and could be broken.
Check if air pressure is 0.7MPa at Gage of Air Filter Regulator.
If the pressure is less than 0.7MPa, Drive-on Plates may not lower correctly.

(How to Drain)

Push up Drain Valve. Water comes out with air during the valve pushed up.

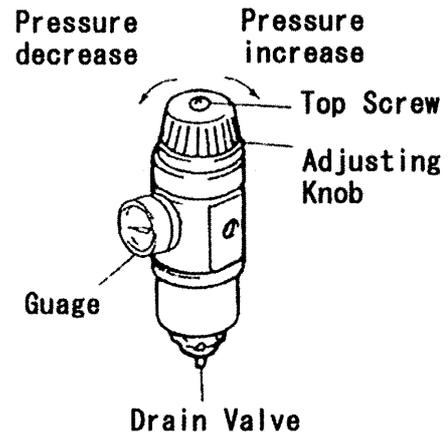

9 Operation Instructions

Process in Servicing Vehicle

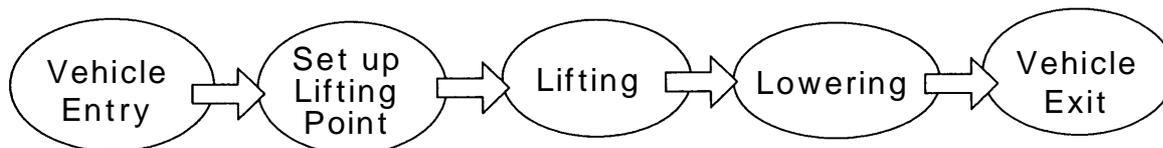

1. Vehicle Entry



Cautions

- When vehicle enters, Drive-on Plates must be fully lowered.
- Locate vehicle so that CG of the vehicle and lift center would be in the same spot. Then vehicle would be stable.

CG = Center of Gravity

Vehicle must be positioned evenly so that CG of the vehicle and lift center would be in the same spot according to the vehicle models.

To locate CG of the vehicle, refer to the service manual of the vehicle or contact vehicle manufacturer.

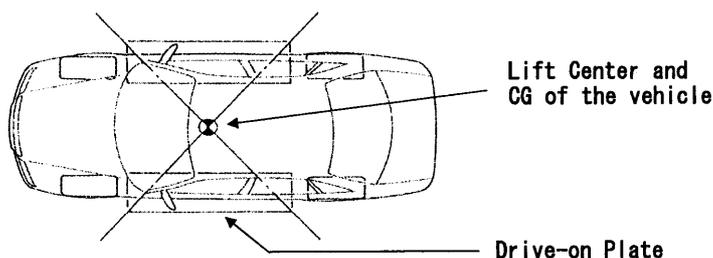

2. Set Up Lifting Point



Caution

Support vehicles on lifting points which is designated by vehicle manufacturers when lifting them up. Do not lift up vehicles on other points, or vehicles could be deformed or broken.

DO NOT lift vehicle if you are in doubt on its CG position.

- Put Side Sill Blocks between Drive-on Plates and lifting points of vehicle.

(Adjustable Drive-on Plate Type)

- First, lift up Drive-on Plates until they completely come out from the ground. Then slide the Plate and put Side Sill Block between Drive-on Plates and lifting points of vehicle.

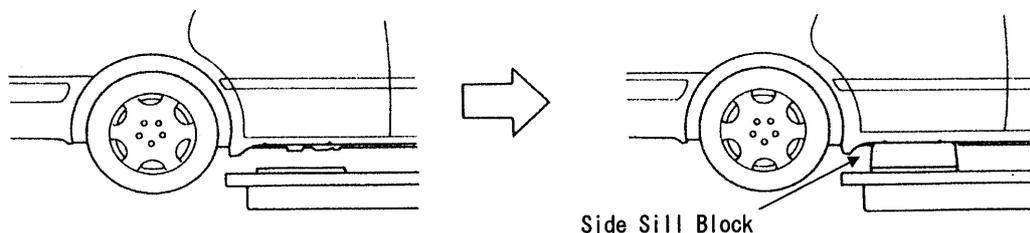

3. Lifting



Warning

Do not lift up any load which is heavier than lift's Capacity.

Lift could be broken.

Make sure there is no one and nothing around lift before operation, or it could result in serious accident.

- 1 Push "UP" button switch and lift up Drive-on Plates. Stop the operation just before Side Sill Blocks touch lifting points of vehicle. Then check again if the Blocks are positioned under lifting points.
- 2 If not, adjust them to proper position.
- 3 If they are, lift up Drive-on Plates until tires of vehicle come off from the ground (about 2-3cm).
- 4 Swing vehicle up and down gently and slowly in order to check if vehicle is well-balanced. If so, lift vehicle up to the height for work.
- 5 Release "UP" button immediately when Drive-on Plates reach max. height.

4. Lowering



Danger

Do not go under vehicle during operation.

If not, it may result in personal injury accident.



- Push "DOWN" button. Then Lowering Stop Hook get released and Drive-on Plates lower. When you stop pushing the button, Drive-on Plates stay in that height level, and Lowering Stop Hooks get hooked in Lowering Stop Racks.
- If Lowering Stop Hooks do not get released because they are deeply hooked in, lift up the Plates a little and push "DOWN" button again.

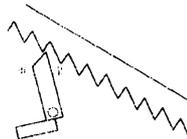

Re-raise the Plates
if Hooks don't get released.

- 1 In case that Adjustable Drive-on Plates are extended, stop lowering once when tires of vehicle reach the ground and the Plates leave off from vehicle.
- 2 Remove Side Sill Blocks and return the Plates to minimum lengths.
- 3 Restart lowering the Plates again to the bottom.

5. Vehicle Exit



Caution

Make sure that Drive-on Plates are fully lowered before vehicle exit.

If not, it may result in damaging vehicle and Lift.

Make sure that there is no tools or other objects under vehicle and inside of pit before vehicle exit.

10 Clean Up After Service Work

Check condition of rubber supporters after service work.
 Keep them clean and free of oil and grease.
 If any abnormality is found, contact your supplier.
 For safety, turn off the circuit breaker.

11 Regular Inspection

| Period | Parts | Items to be inspected | Inspection Method | |
|-----------------|---|---|--|---------------|
| Every Month | Bolts, Screw & Nuts etc. | Looseness | Tightening | |
| | Air Circuit | Joint, Air Tube, Air Pressure Equipment | any leak of drain or air inside of the circuit | |
| | Lowering Stop Device | Movement of the Safety Hook Release Cylinder | smooth movement of the parts | |
| | Lubricate the parts and points shown on page 16. | | | |
| Every 3 Months | Control Box | Electric components (Magnet Switch, Relay etc) | movement, dirt at contact point, crack | |
| | Oil Tank | Suction Filter | clog | |
| | Pipeline, Air Hose and parts around them | Joint | any leak of oil or air | tightening |
| | | Pipe Line, Hyd. And Air Hoses | any crack, oil leakage | replace parts |
| | Scissors Link and Drive-on Plates | Wear of bearings | looseness at bearing | |
| | | Rotation of Roller | offset wear at rollers | |
| | | Link and Drive-on Plates | crack, twist, damage, distortion | |
| Hyd. Cylinder | Oil Leak | leak from dust seal, joint | | |
| | Natural Lowering | Lift up vehicle and check the lowering (1 mm/5 Minutes) | | |
| Base | Looseness of Anchor Bolt Level Adjustment | tightening and adjusting level | | |
| Every 12 Months | Oil Tank and Synchronizing Cylinder | Oil | Oil conditions | |
| | | Oil volume | | |
| | Replace oil in 3 months after installation, then replace every year | | | |
| | Side Sill Block | Side Sill Block | crack, deforming | |

Hydraulic Oil

Quality of Hyd. Oil is very important for the performance of the gear pump used for the lift and the recommendable oil are as below or equivalent.

Viscosity - ISO VG32 Oil Volume - 13 liters

| | |
|-------|------------------------------|
| Esso | Unipower SQ32, XL32 |
| Shell | Telus Oil 32, K32, W-R Oil32 |
| Mobil | Mobil DTE24 |

12 Trouble Shooting

Do not operate lift if you suspect that there is a malfunction.
Contact your supplier.

| Symptom | Possible Cause | Action |
|---------------------|---|---|
| Lift does not rise | Motor does not rotate | Solve the problem and then reset |
| | •Thermal Relay is disconnected | Solve the problem and then replace magnet switch |
| | •Contacting point of magnet switch is burnt | Check the voltage and solve the problem |
| | •Power is single phase | Repair the cut off |
| | •Electric circuit is cut off | |
| | Motor rotates | Remove foreign objects |
| | •Roller at bottom of link is stuck with foreign objects | |
| Lift does not lower | •Lack of oil | Fill the oil |
| | •Suction Filter is clogged | Clean or replace Suction Filter |
| | •Gear Pump does not take in oil | Replace Gear Pump |
| | •Oil leak from pressure oil pipe | Tighten joints or replace the parts |
| | •Oil leak from Seal of Cylinder | Replace the Seal |
| | •Lowering Stop Hook is engaged | Lift up Drive-on Plates to release |
| | •Roller at bottom of link is stuck with foreign objects | Remove foreign objects |
| Natural Lowering | •Control Cable is cut or became longer | Adjust or replace the Cable |
| | •Air pressure is not adjusted to 0.5MPa | Check if air supply is more than 0.5MPa and adjust air pressure at Air Filter Regulator to 0.5MPa |
| | •The lowering 0.5mm/5 mitutes is within tolerances | Contact supplier if lowering is more than tolerance |
| | •Oil leak from Lowering Valve | Replace seals |
| | •Oil leak from Check Valve | Clean up or replace the Valve |
| Noise | •Oil leak from Seal of Cylinder | Replace the Seal |
| | •Oil leak from pipelines | Find leaking spot and repair the |
| | •Hand Control Lowering Valve is loosen | Shut off the Valve with L-shape Hook which is attached |
| Noise | •Lack of lubrication at bearing | Lubricate |
| | •Wear of the roller at link | Replace roller |
| | •Lack of Hyd. Oil in Cylinder | Fill the oil and lift up to top without load |

Lubrication Points

Lubricate the below points with grease every month.

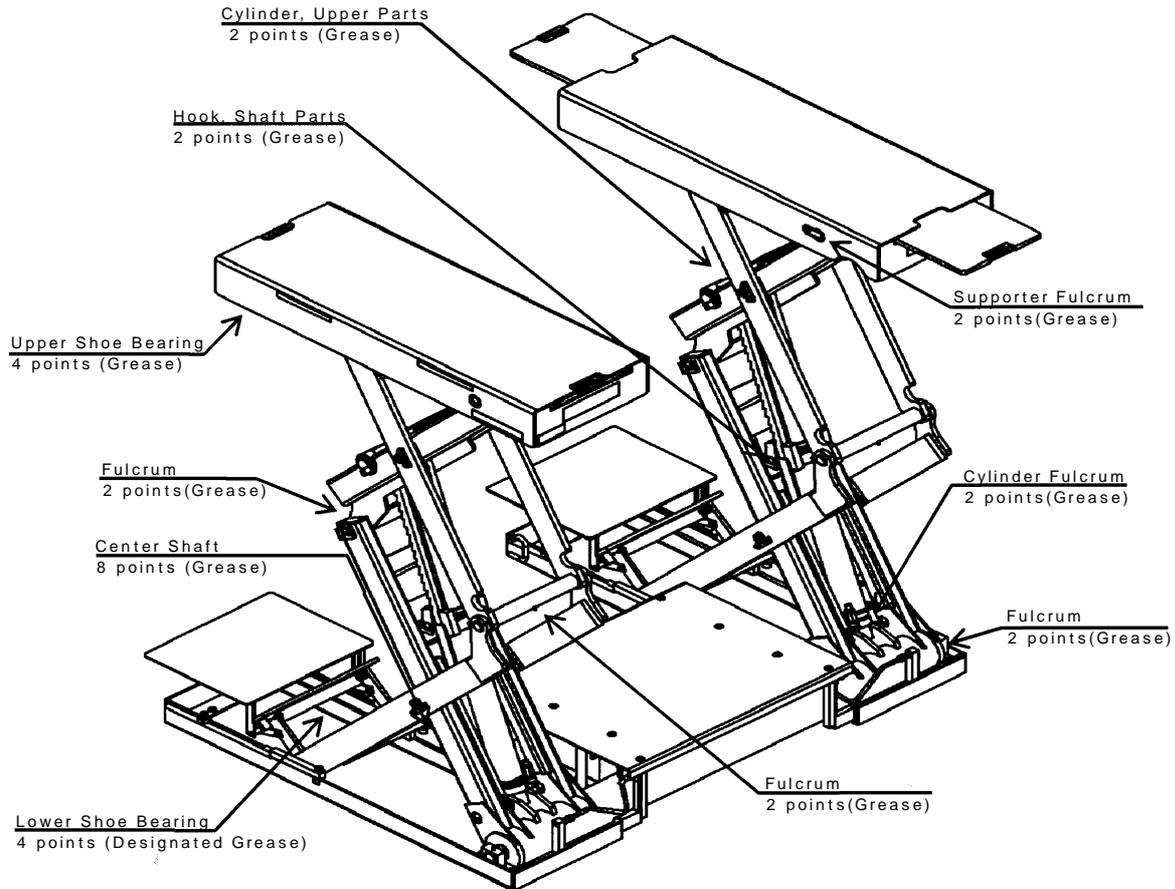

Lower Shoe Bearing have to be lubricared with designated grease.
: Grease with Molbdenum included

13 Specification

Note: Specifications could be changed without notice.

| Specification | Adjustable Drive-on Plate Type |
|---------------------|---|
| Model | BSC3200KU |
| Capacity | 3200 (kg) |
| Applicable Vehicle | Passenger Vehicle Only |
| Vertical Travel | 1800 (mm) |
| Drive-on Plate Size | (1320 ~ 1870)L x 470W (mm) |
| Power | 3PH/200V/380/400/415/440V/50Hz/60Hz 415V-50Hz 440V-60Hz Only |
| Motor | 2.2 kW 4P /10min. Rating |
| Oil | Viscosity - ISO VG32 |
| Oil Volume | 13 (L) |

BSC3200KU

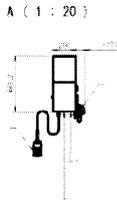
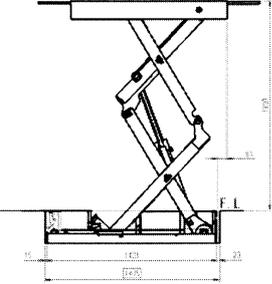
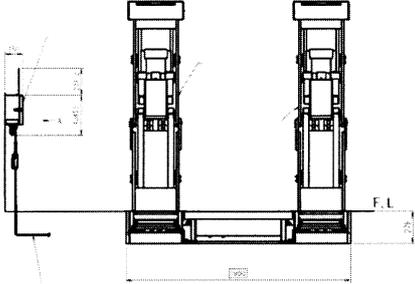
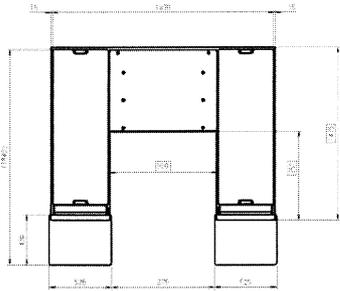
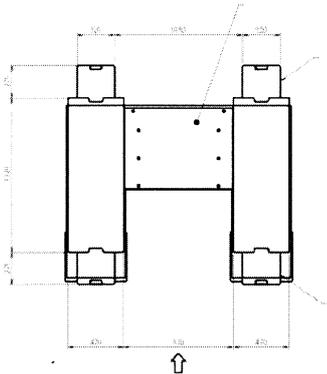

14 Warranty

We warrant the products manufactured by Sugiyasu Corporation to be free from defects in workmanship and material for 1 year.

Our obligation under this warranty is limited to repair or replacement, at our option, of any parts or material which, within this warranty period, are found to our satisfaction to be defective.

The belows are not covered by the warranty.

- 1 The damage or trouble caused by the false operation, negligence of the maintenance and storage required.
- 2 The damage or trouble caused by the modification that affects the originally designed functions.
- 3 Any consumable parts that need to be replaced.
- 4 The damage or trouble caused by natural disaster such as fire, earthquake, flood etc.
- 5 The damage or trouble caused by not using the original manufacturer's parts.
- 6 The required information such as serial No. etc. would not be provided.
- 7 The damage or trouble caused by improper installation.

Any consumable parts such as rubber parts etc. are not covered under this warranty.

As this lift is not weatherproof, trouble caused by corrosion, rust, short circuit from water are not covered under this warranty.

How To Claim

Contact your lift supplier.

15 After Service

- Something is wrong
- Something is still wrong
- Repair under warranty period

- Repair after warranty period
- Availability of Spare Parts

Check in accordance with this manual
 Contact your supplier for repair
 Will be repaired in accordance with warranty rules
 Contact your supplier
 The spare parts is available for 8years after discontinuing manufacturing

Contact your supplier for any information regarding to the after service.
 When contacting your supplier, provide Model No., Serial No., purchase date and conditions of trouble.

For your records and future contact, fill out below.

| | |
|---------------------------------------|--------|
| Model No. | |
| Serial No.. | |
| Purchase Date | |
| Supplier Name Address Tel. No. | |
| Installer Name Address Tel. No. | |
| Trouble Date and conditions | Date : |
| | Date : |
| | Date : |
| | Date : |
| | Date : |

16 Installation and Relocation

Contact your supplier for installation and relocation of the lift.
 In case relocation, perform the inspection by supplier.



3-21,4-CHOME,HONGO-CHO,TAKAHAMA CITY,AICHI,JAPAN 444-1394
TEL (0566) 53-1126 FAX (0566) 53-1844
<http://www.bishamon.co.jp/>



EOM-BSC 1102 0502 200KU